

Infinite Loop Distance Sensor Bot

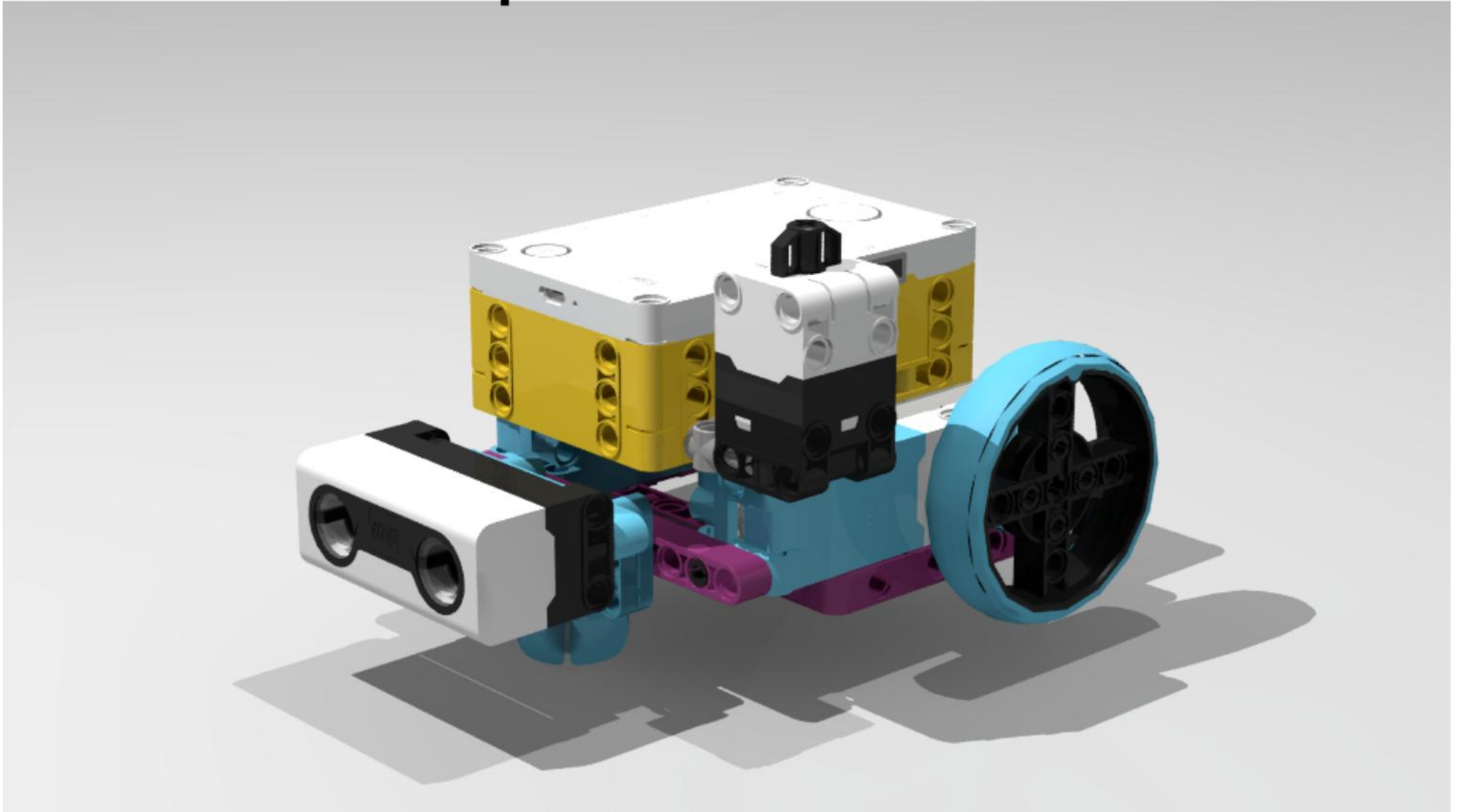

Stand Alone Lesson

Building Instructions by Wesley John Smith

1

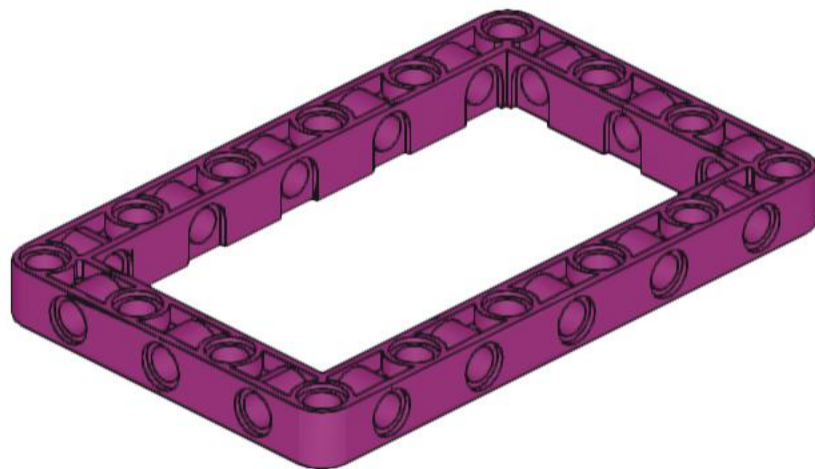
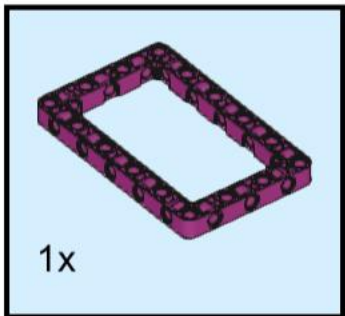

2

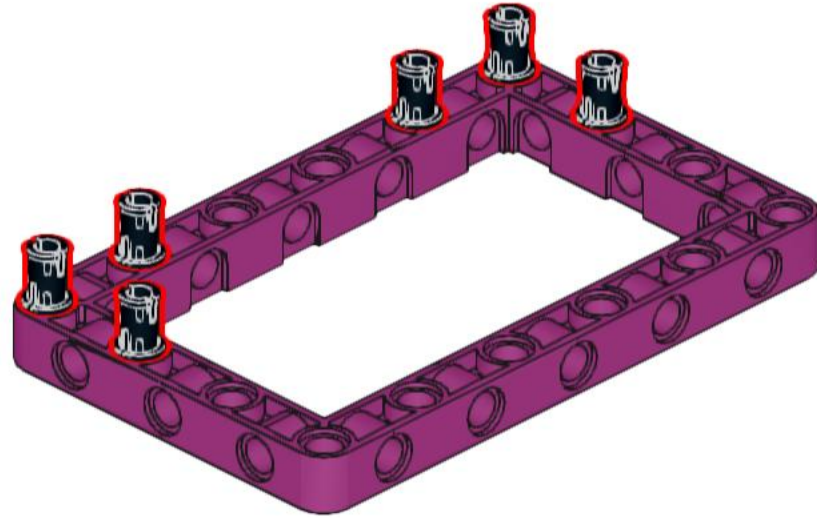

3

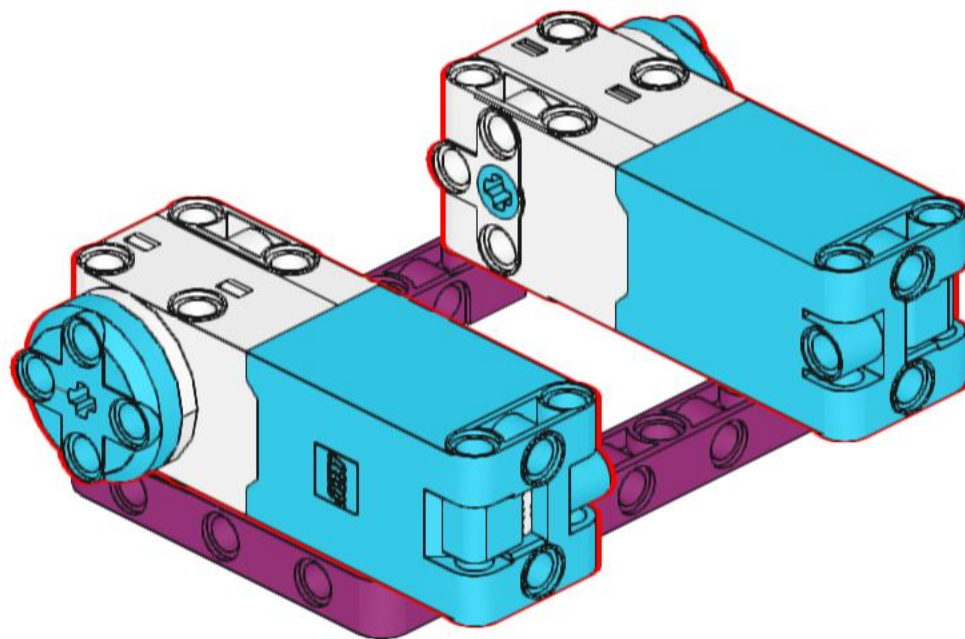
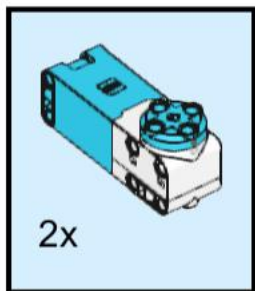

4

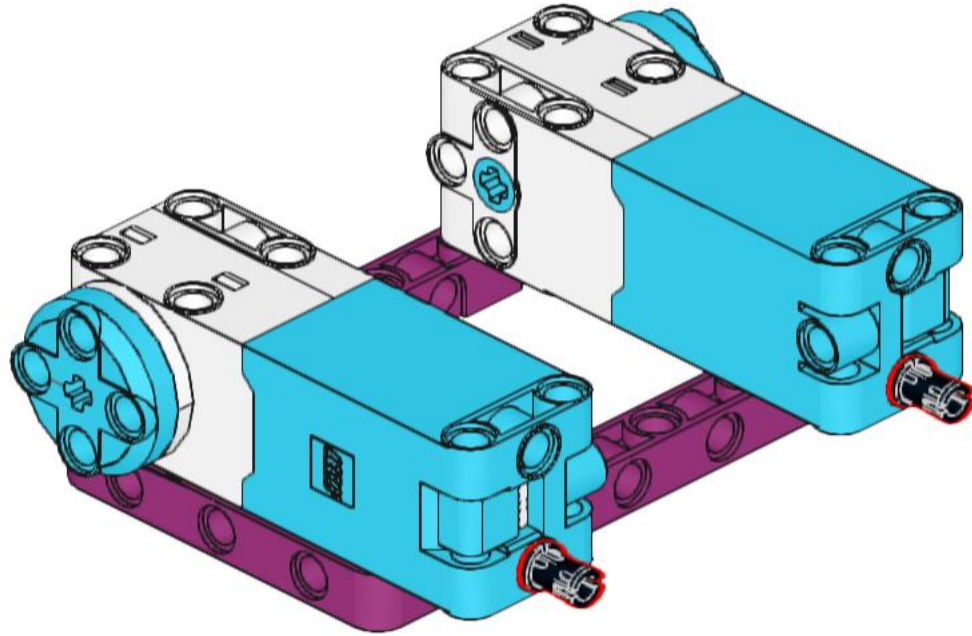

5

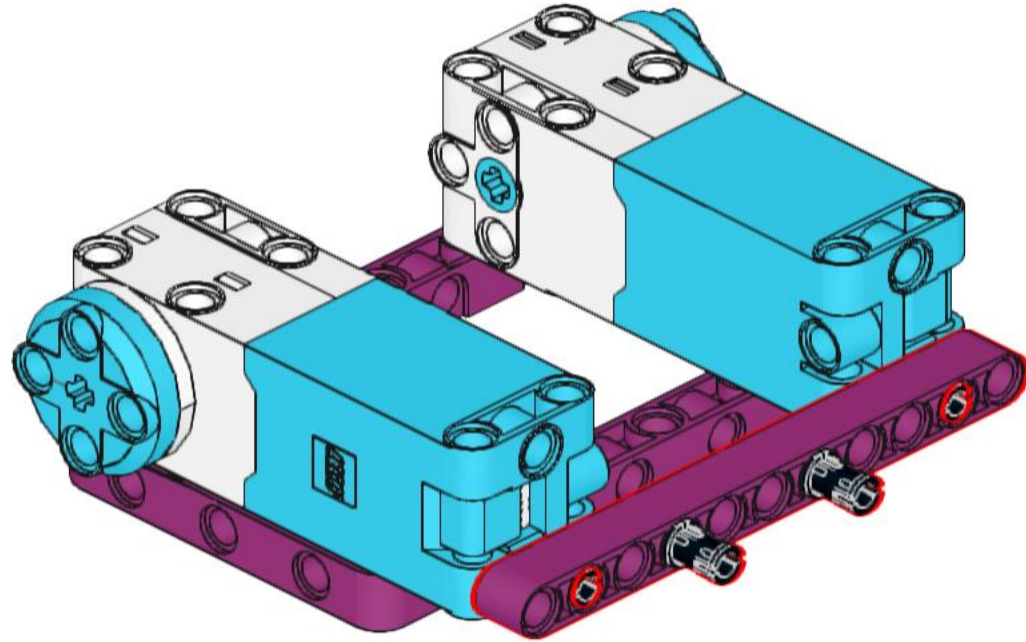
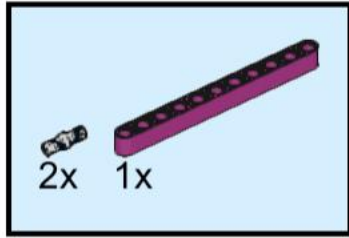

6

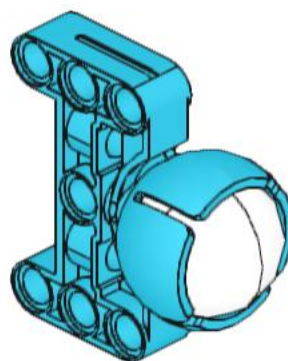
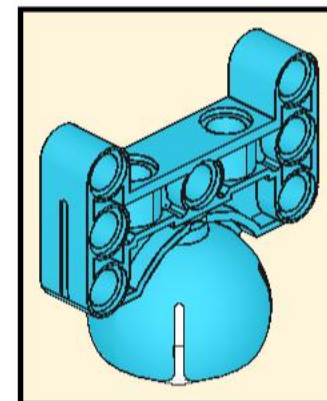
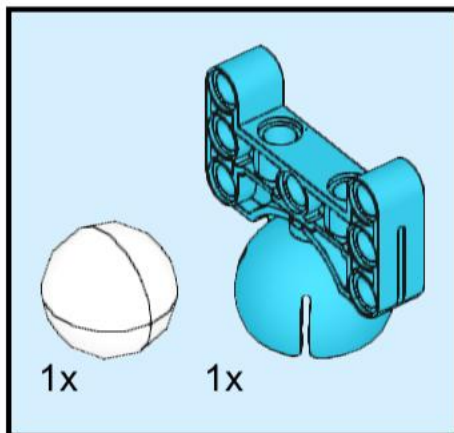

7

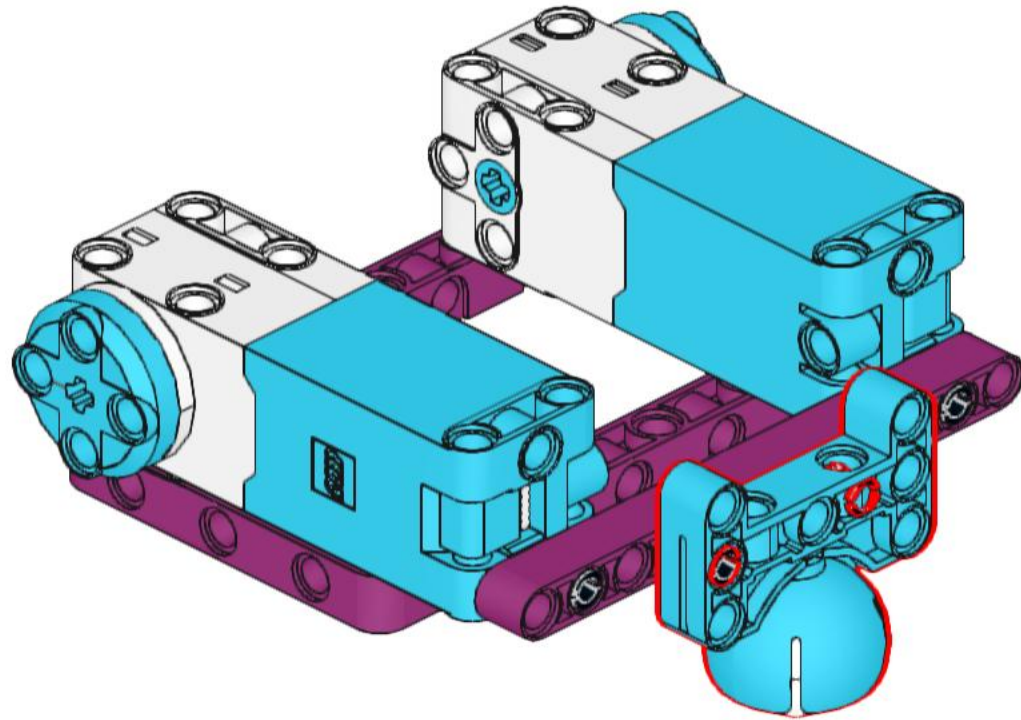

8

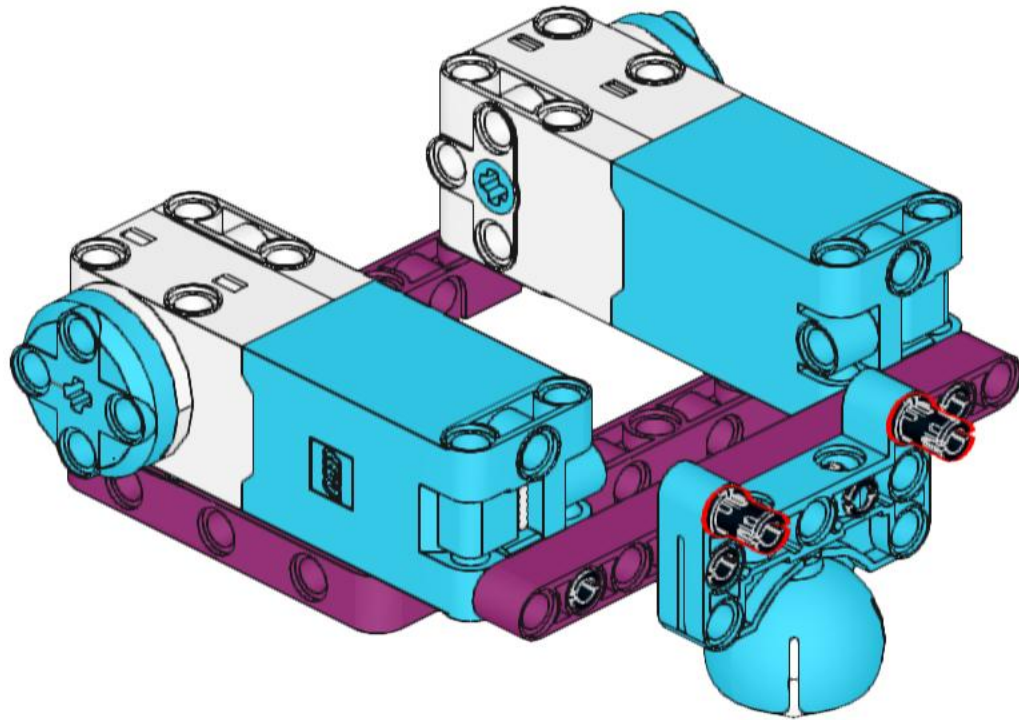

9

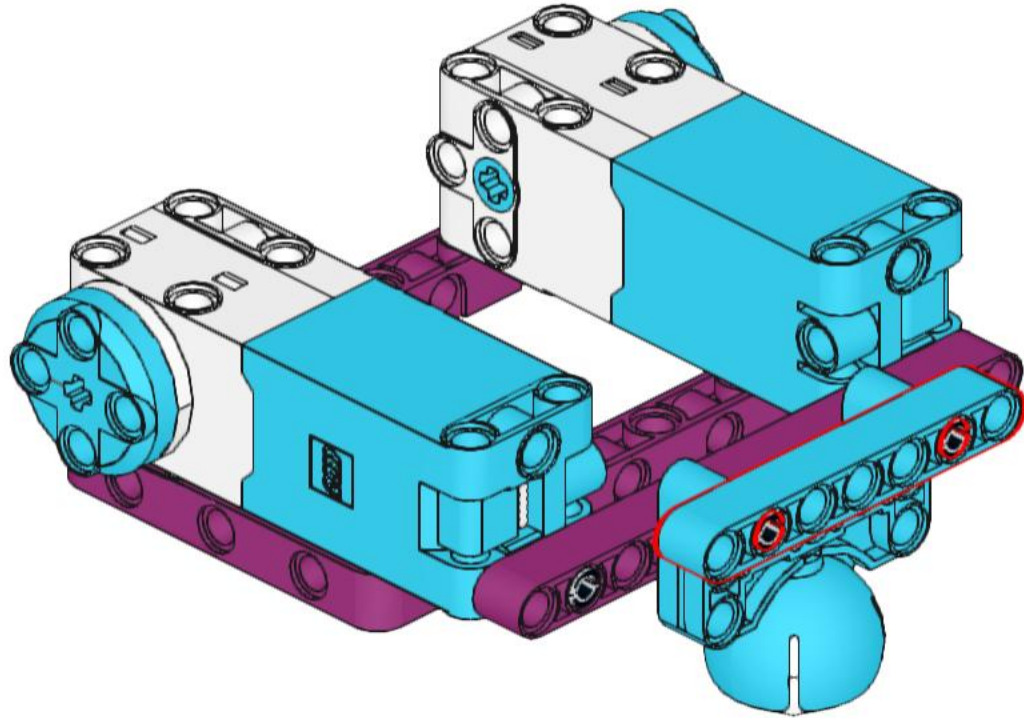
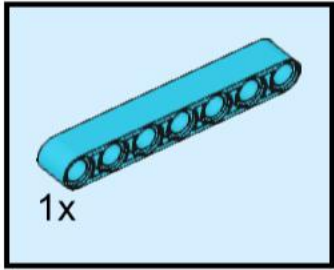

10

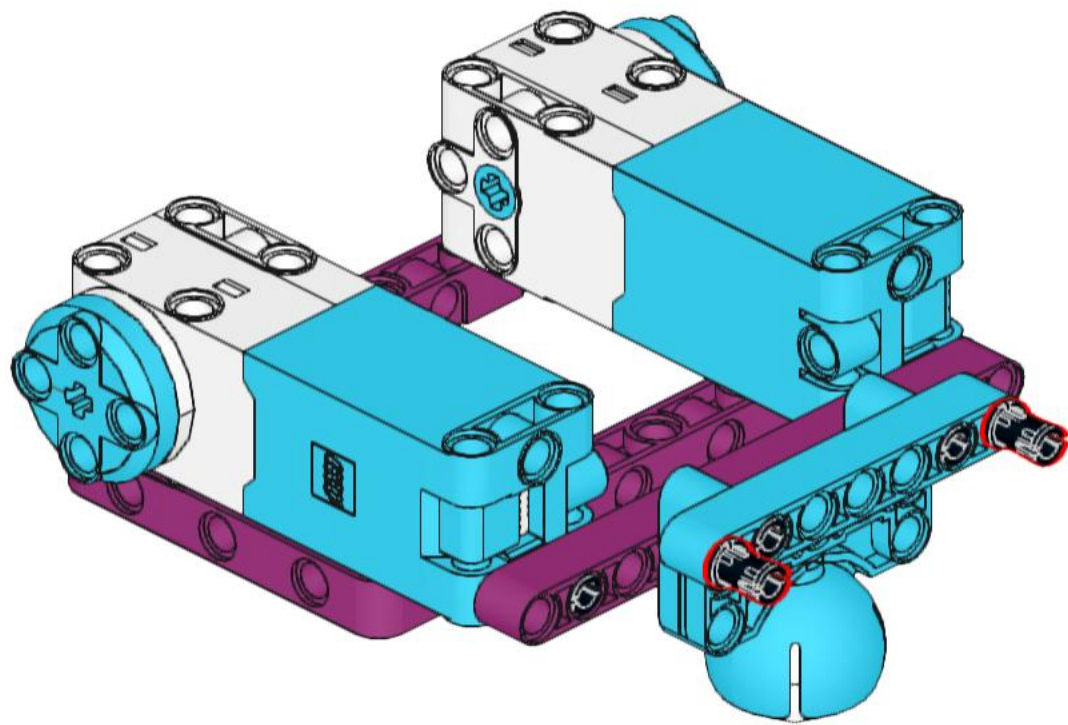

11

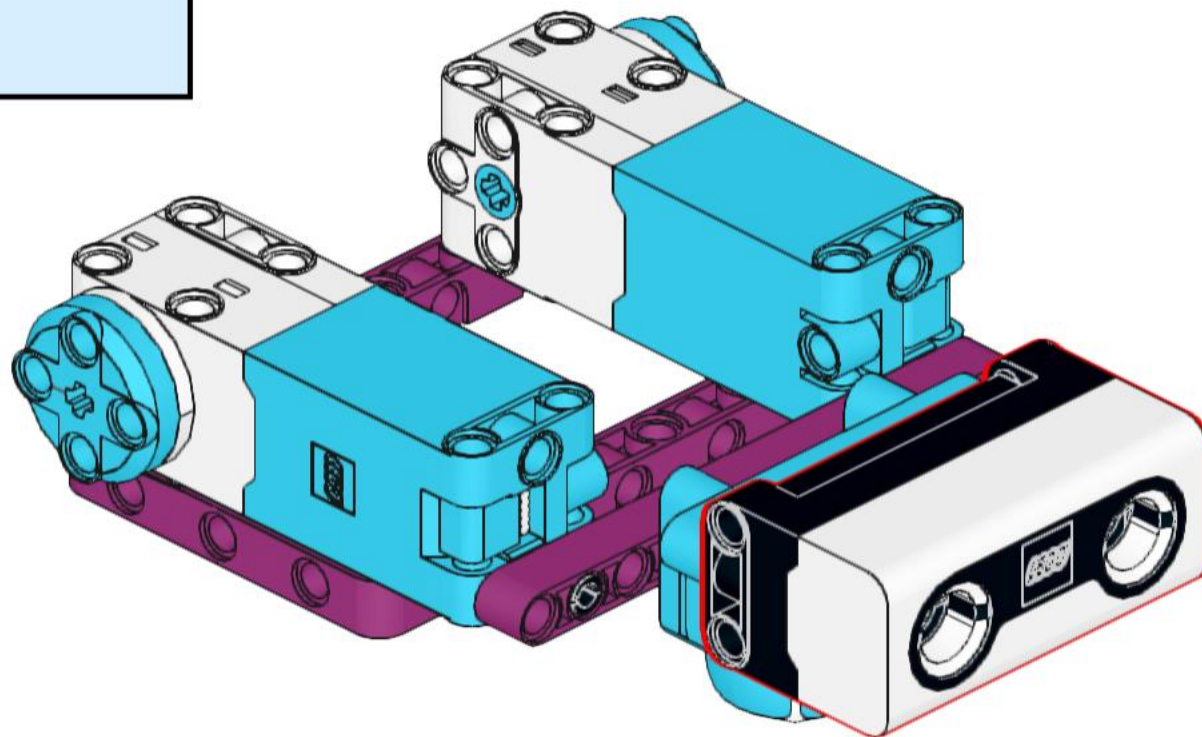
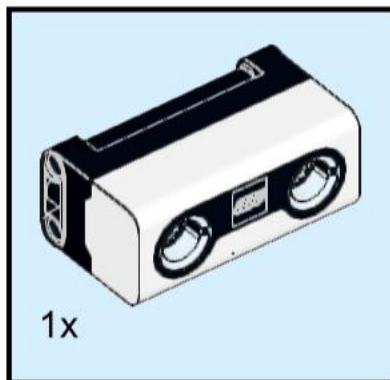

12

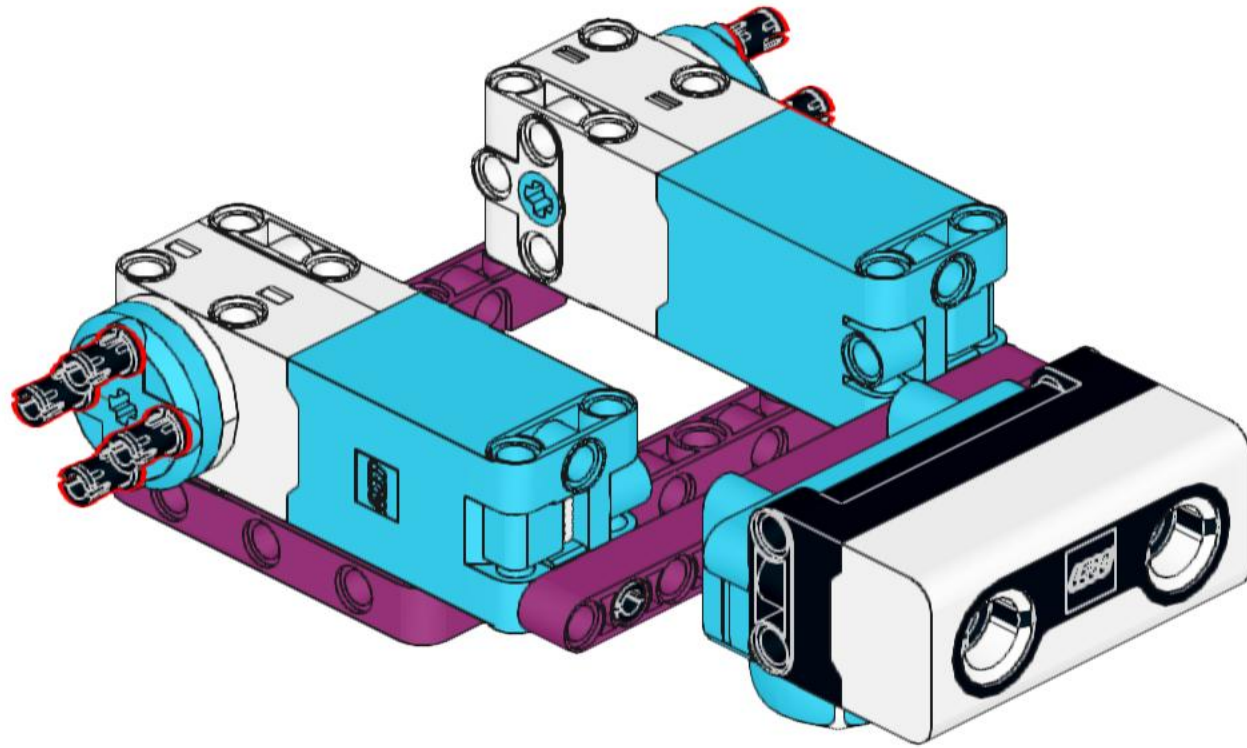

13

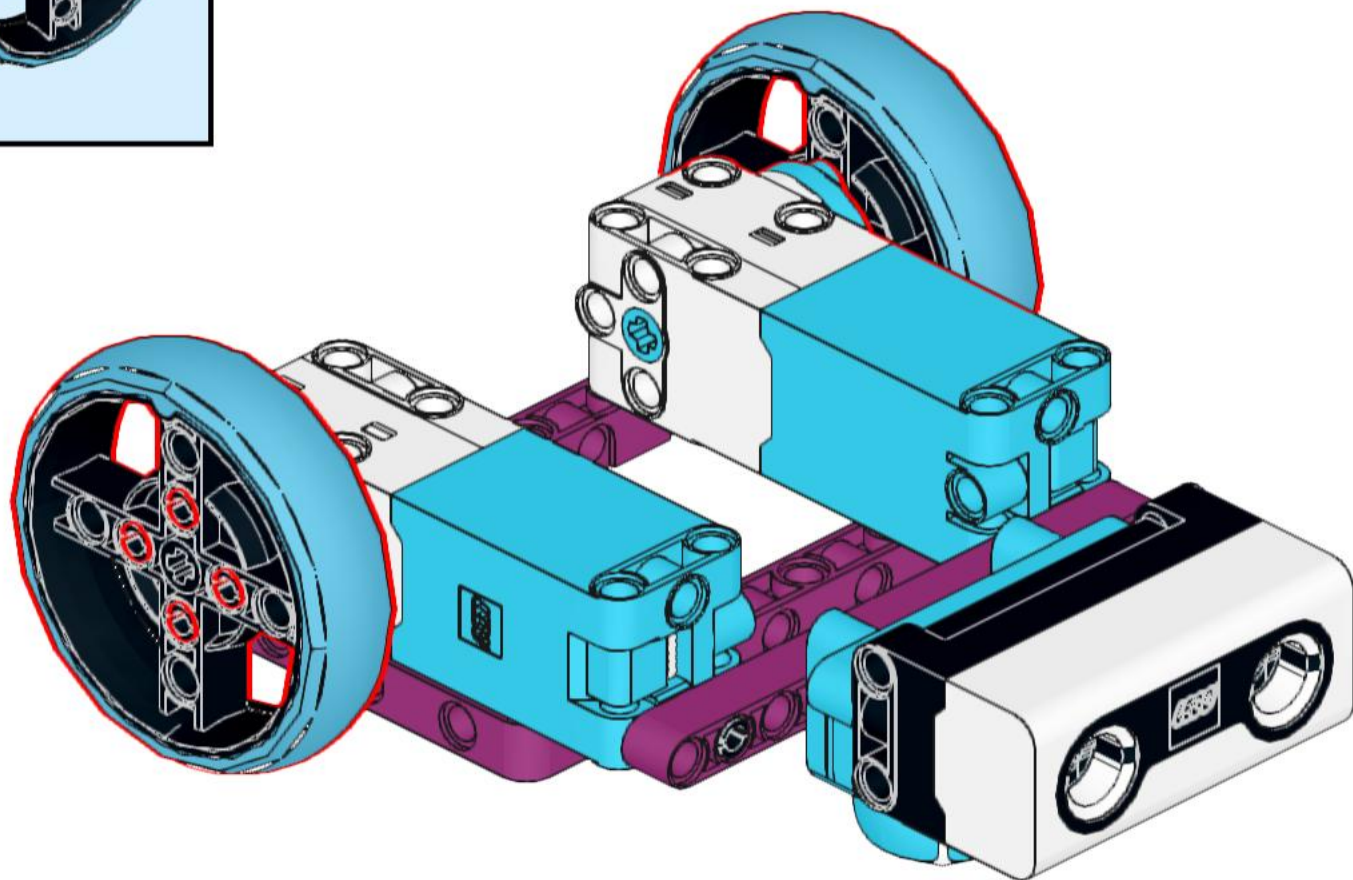
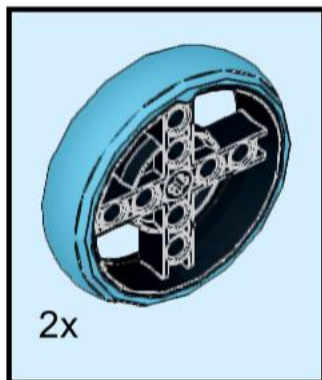

14

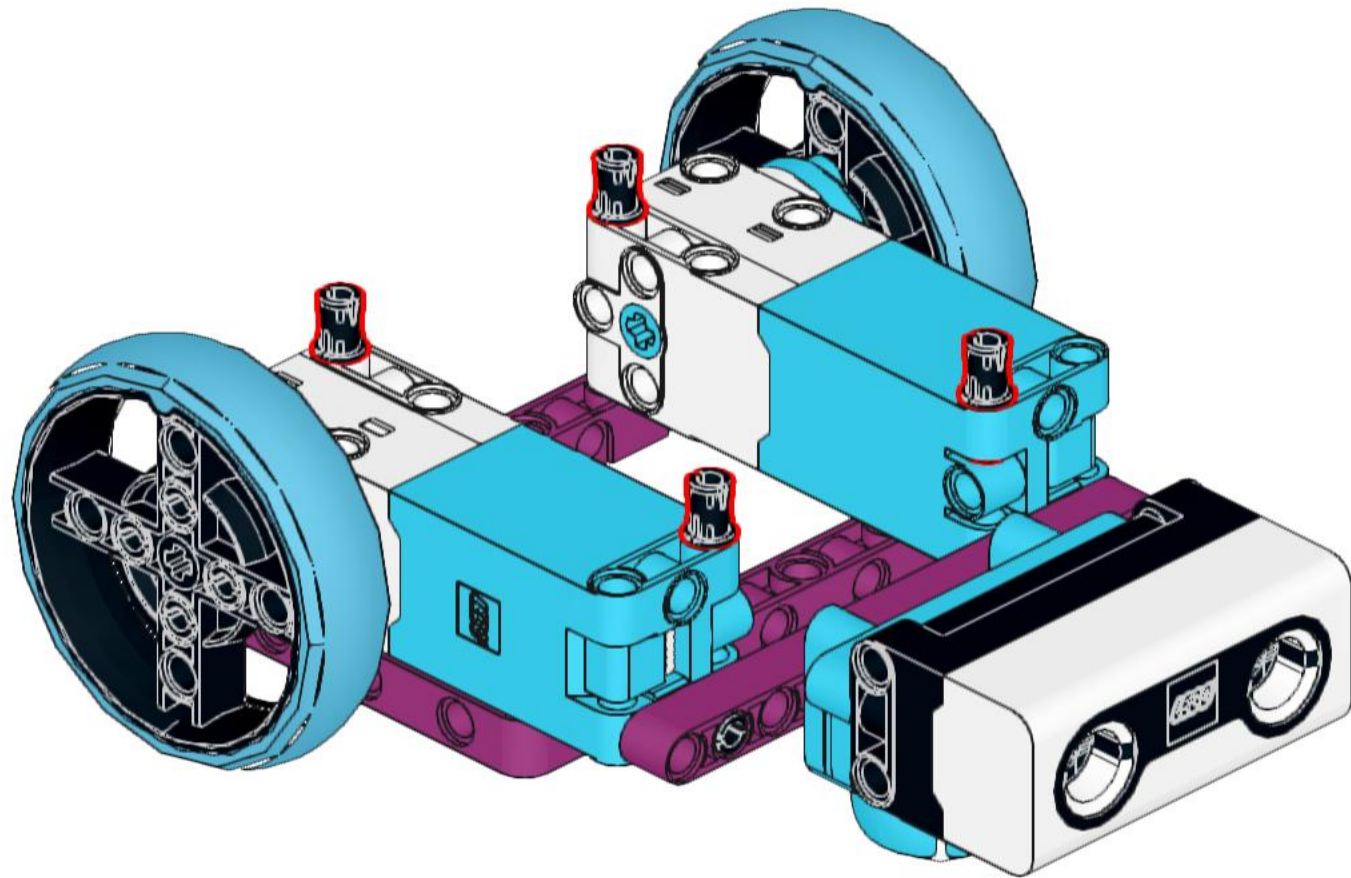

15

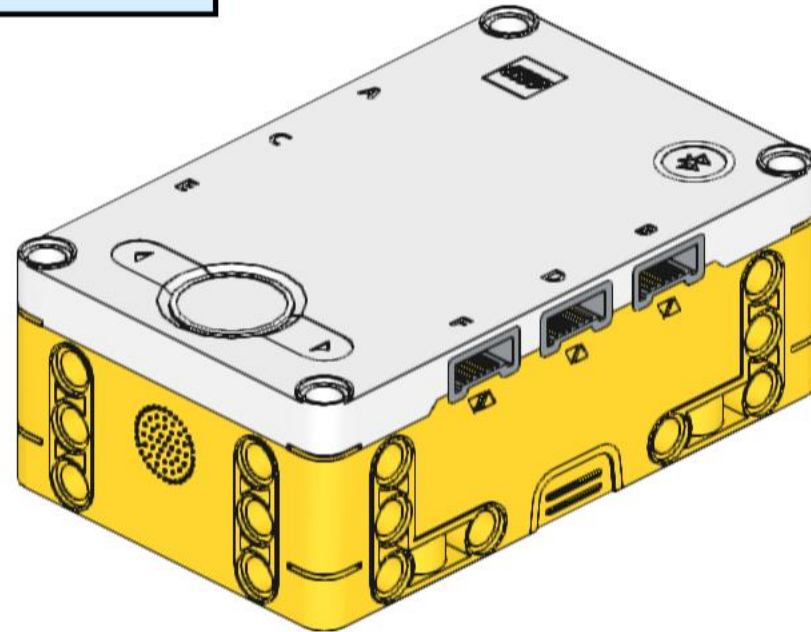
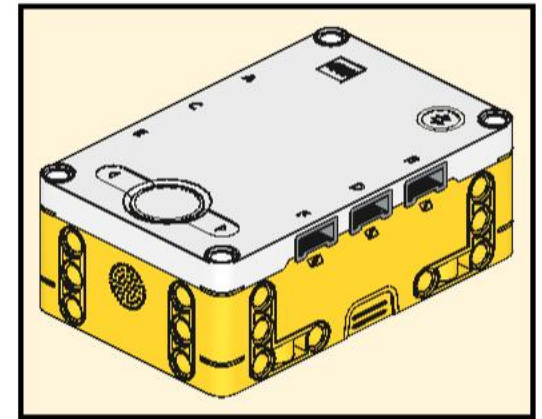
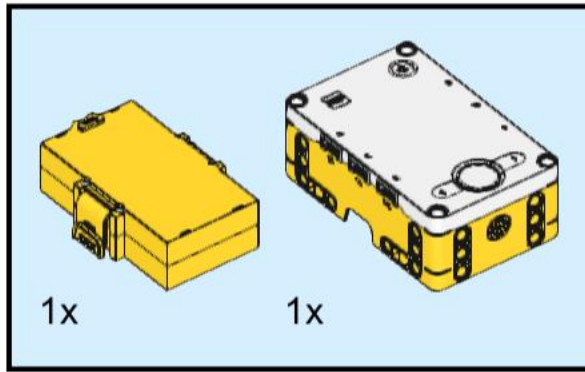

16

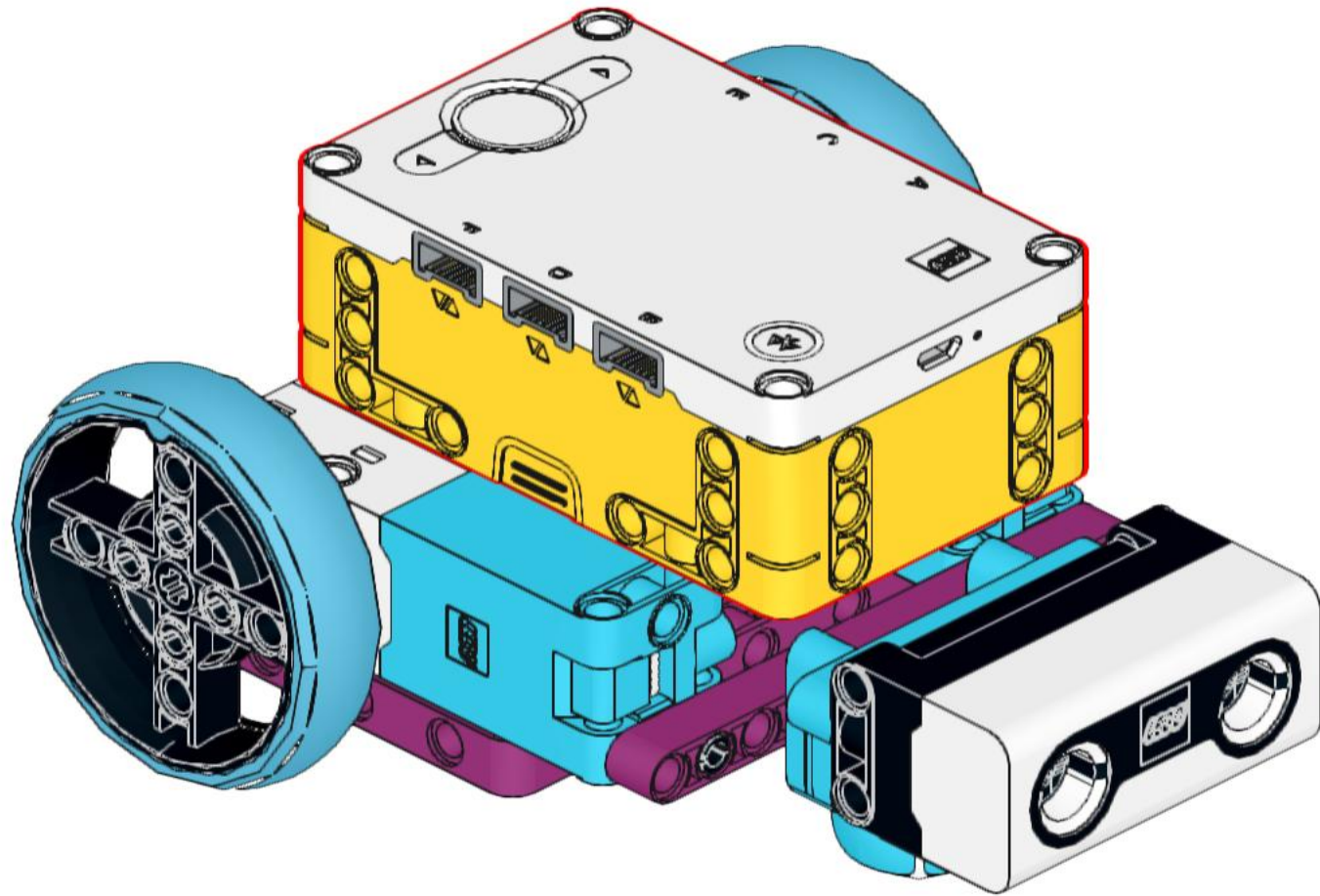

17

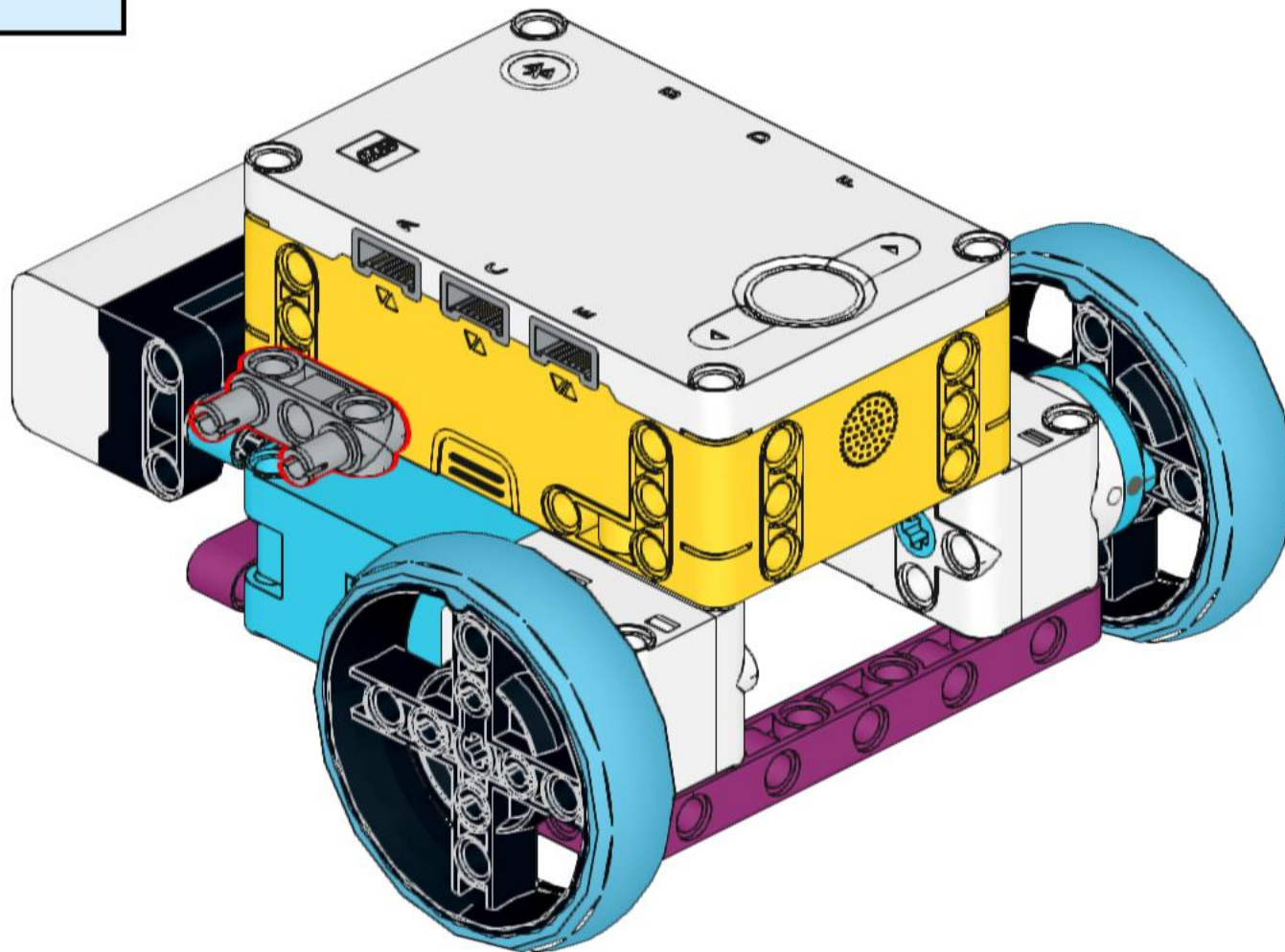
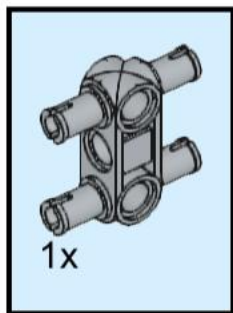

18

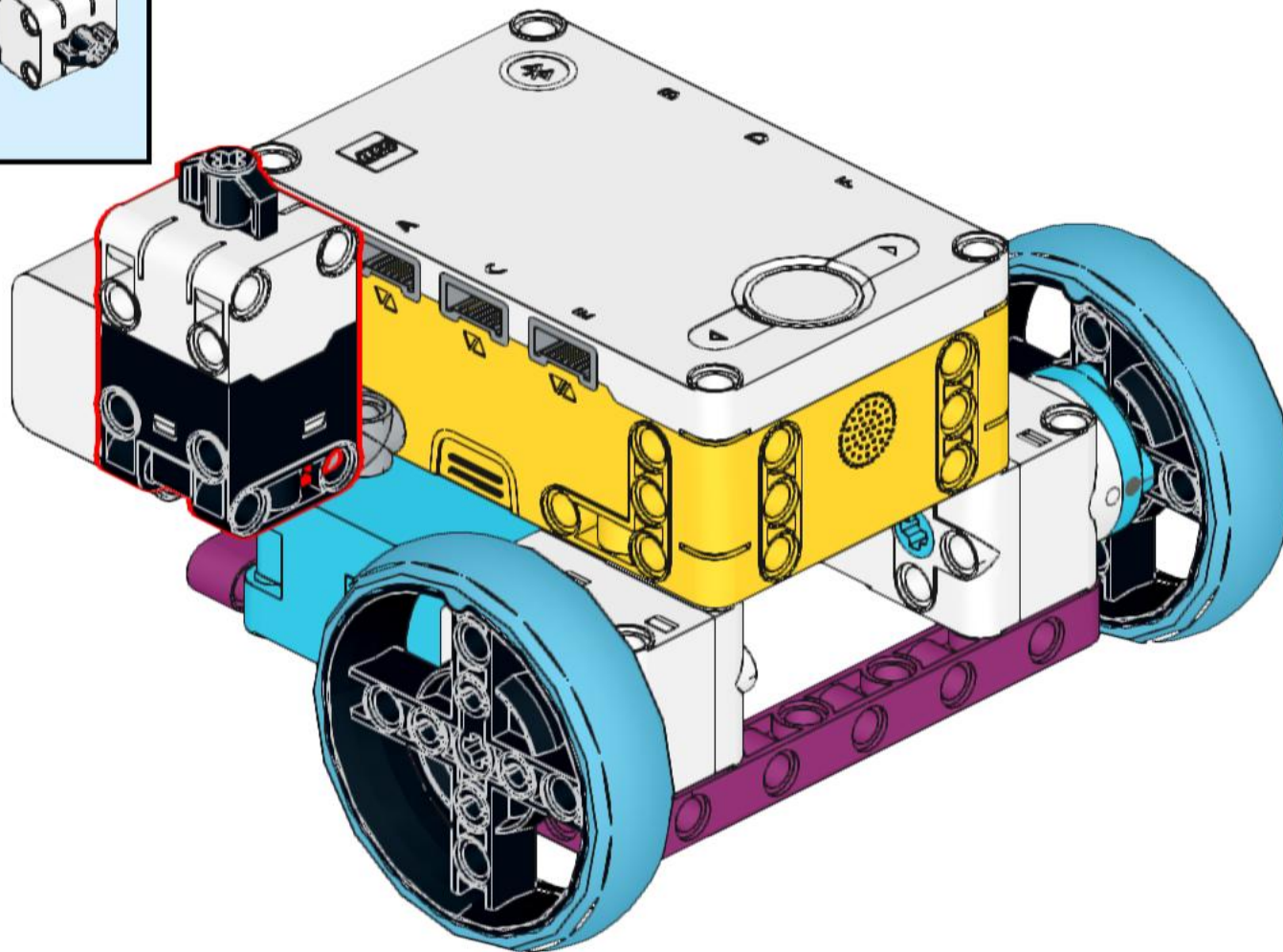
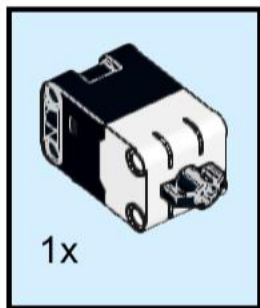

19

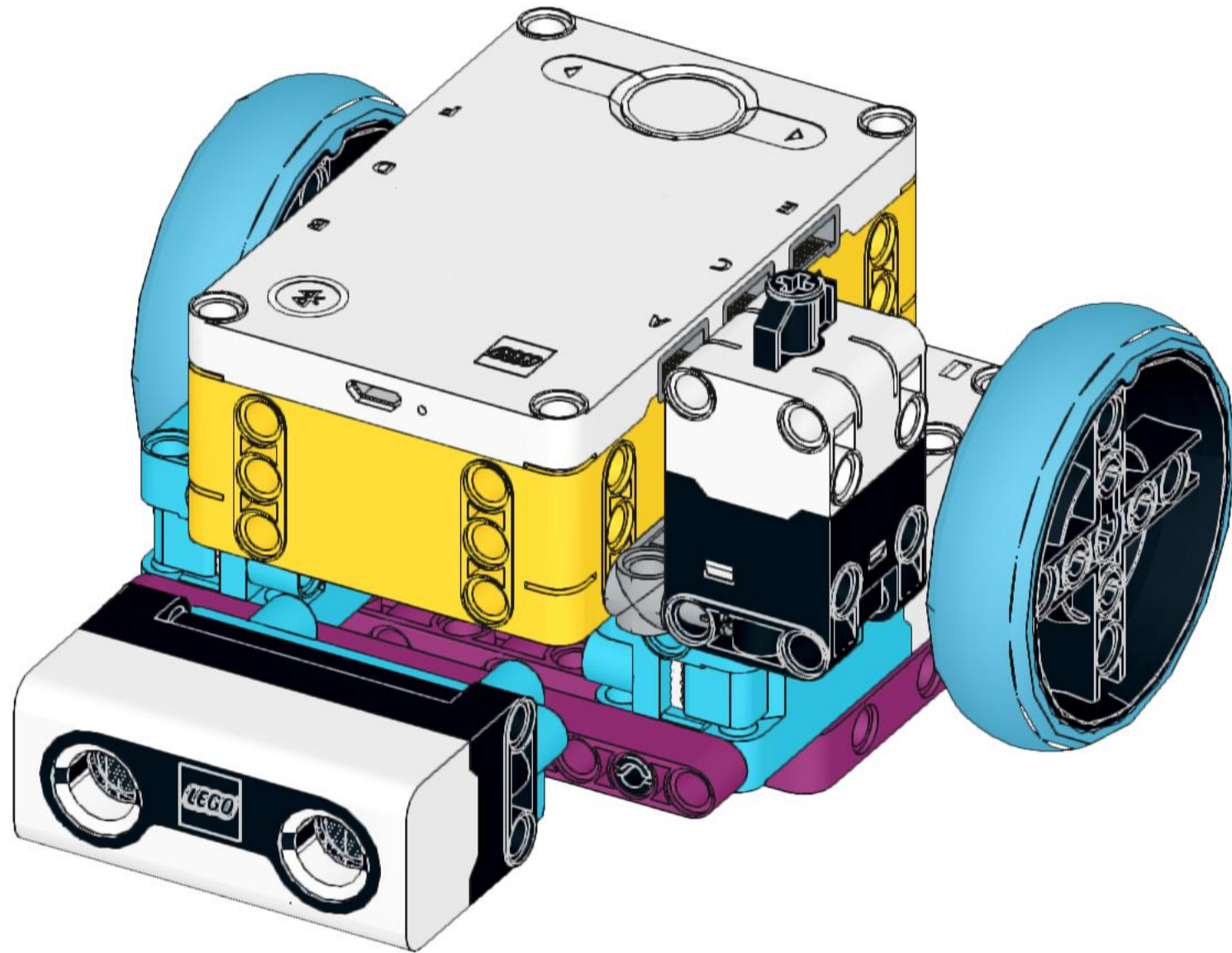

Port Connections

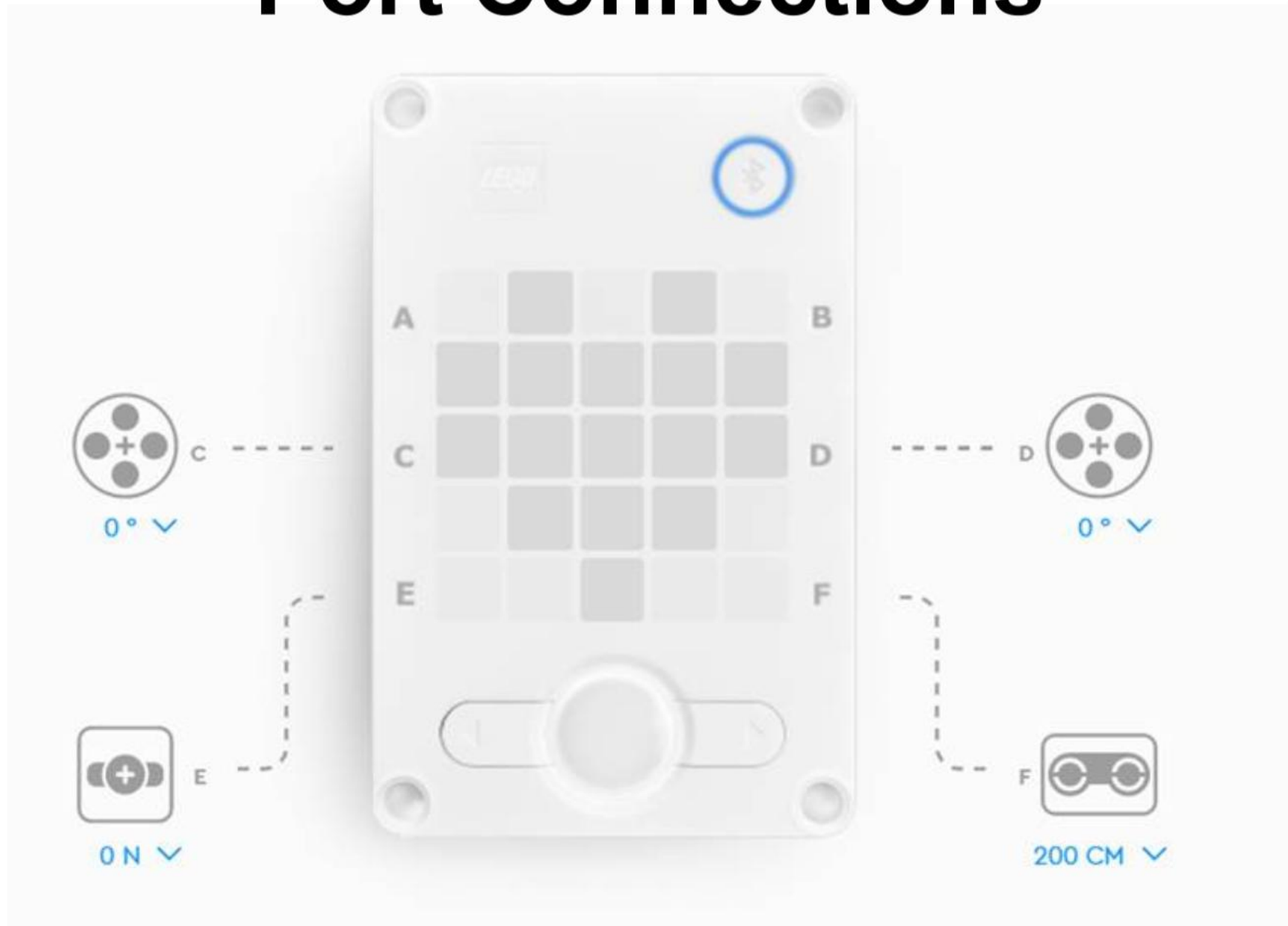

Coding Hints

The image shows a Scratch script for a robot. It starts with a 'when program starts' block, followed by three motor control blocks: 'set movement speed to 50 %', 'set movement motors to C+D', and 'set 1 motor rotation to 17.5 cm moved'. Below this is a 'when E is pressed' block that enters a 'forever' loop. Inside the loop, an 'if' block checks if sensor F is closer than 10 cm. If true, it performs three actions: 'stop moving', 'move down for 3 rotations', and 'move right: 100 for 0.5 rotations'. If false, it performs 'start moving up'.

```
when program starts
  set movement speed to 50 %
  set movement motors to C+D
  set 1 motor rotation to 17.5 cm moved

when E is pressed
  forever
    if F is closer than 10 cm ? then
      stop moving
      move down for 3 rotations
      move right: 100 for 0.5 rotations
    else
      start moving up
```